

# XHBHV

For High Voltages up to 400V DC

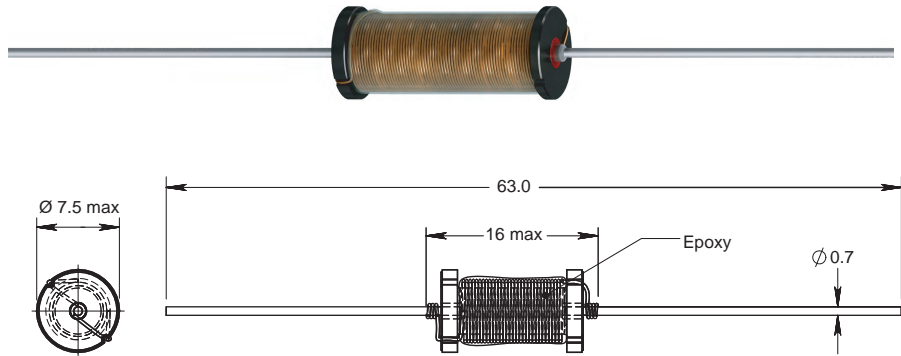

Fixed Choke Coils

Leaded Inductors

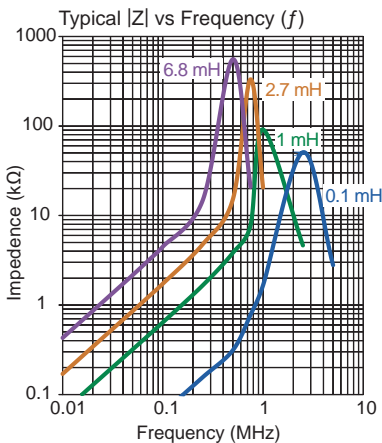
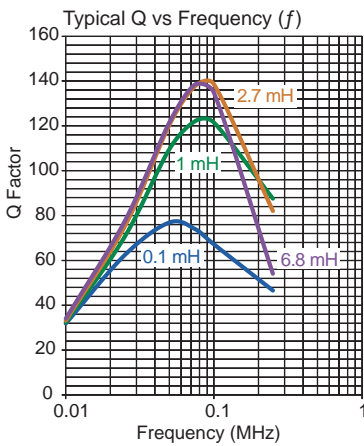
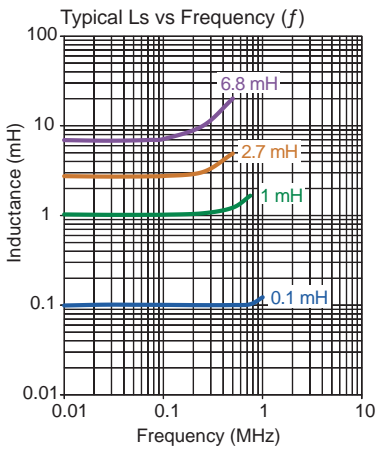

Part No	Inductance L (μH)	$f_L$ (kHz)	Tol ± (%)	Q min	$f_Q$ (kHz)	SRF min (MHz)	DCR max (Ω)	Rated DC Current (mA)	
								$I_1$	$I_{sat}$ typ
XHBHV-101K-YY	100	20	<b>10</b>	30	796	2.81	0.22	1760	1720
XHBHV-151K-YY	150	20	<b>10</b>	30	796	2.45	0.36	1420	1480
XHBHV-221K-YY	220	20	<b>10</b>	25	796	1.98	0.44	1300	1240
XHBHV-331K-YY	330	20	<b>10</b>	25	796	1.63	0.77	1000	1010
XHBHV-471K-YY	470	20	<b>10</b>	45	252	1.45	0.96	900	850
XHBHV-681X-YY	680	20	<b>5,10</b>	55	252	1.18	1.49	730	710
XHBHV-102X-YY	1000	20	<b>5,10</b>	70	252	0.98	2.20	560	560
XHBHV-152X-YY	1500	20	<b>5,10</b>	70	252	0.80	3.29	500	480
XHBHV-172X-YY	1700	20	<b>5,10</b>	65	252	0.75	4.61	480	430
XHBHV-202X-YY	2000	20	<b>5,10</b>	80	252	0.70	4.74	410	420
XHBHV-222X-YY	2200	20	<b>5,10</b>	75	252	0.65	5.04	400	380
XHBHV-242X-YY	2400	20	<b>5,10</b>	65	252	0.62	5.45	390	360
XHBHV-252X-YY	2500	20	<b>5,10</b>	65	252	0.62	5.53	380	350
XHBHV-272X-YY	2700	20	<b>5,10</b>	65	252	0.62	5.76	370	370
XHBHV-302X-YY	3000	20	<b>5,10</b>	55	252	0.58	6.22	360	330
XHBHV-332X-YY	3300	20	<b>5,10</b>	55	252	0.55	6.52	345	310
XHBHV-352X-YY	3500	20	<b>5,10</b>	55	252	0.50	7.37	330	310
XHBHV-362X-YY	3600	20	<b>5,10</b>	50	252	0.50	7.44	325	290
XHBHV-452X-YY	4500	20	<b>5,10</b>	45	252	0.45	9.48	290	260
XHBHV-472X-YY	4700	20	<b>5,10</b>	40	252	0.42	9.74	285	260
XHBHV-532X-YY	5300	20	<b>5,10</b>	45	252	0.40	12.23	255	250
XHBHV-682X-YY	6800	20	<b>5,10</b>	100	79.6	0.38	14.16	220	220

Core Material : Ferrite

Revision date : 20 Jul 2018

SPQ :

Packing Form	Taped / Reel	Taped / Ammo pack
Axial	800 [-01]	300 [-02]

Remark :  $I_1$  &  $I_{sat}$  - see description in Technical Data