

1210 FTC

Transponder Coil

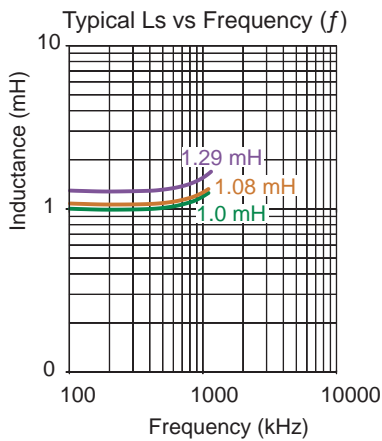
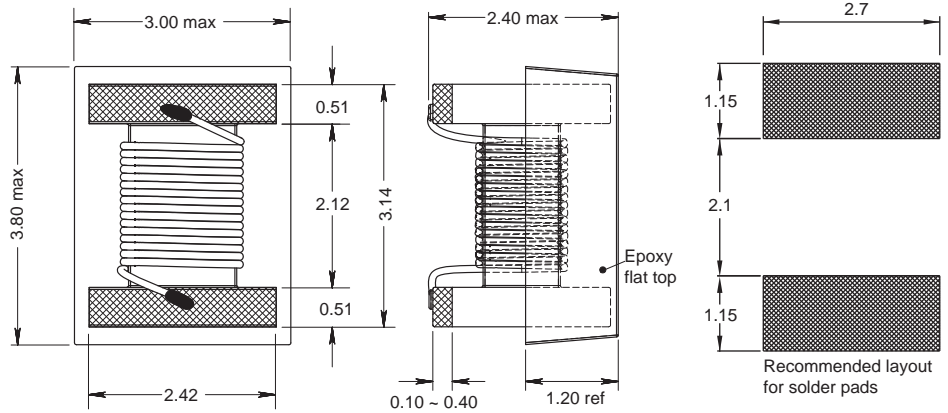
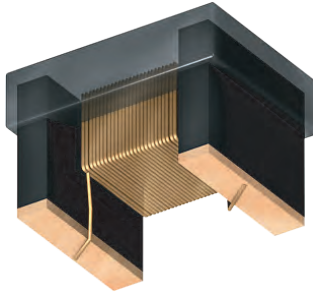

Part No	Inductance	f_L	Tol	Q	f_Q	SRF	DCR	Sensitivity
	L (mH)	(kHz)	\pm (%)	min	(kHz)	typ (MHz)	max (Ω)	mV/ μ T
1210FTC-102K-YY	1.00	125	10	8	125	1.7	32.0	10
1210FTC-112K-YY	1.08	125	10	8	125	1.7	42.0	12
1210FTC-132K-YY	1.29	125	10	8	125	1.7	46.5	12

Core Material : Ferrite

Revision date : 03 Sep 2020

SPQ : Taped / Reel 800 [-01]
3000 [-04]

Remarks: - Unlisted inductance values available upon request.
- 5% tolerance available upon request.

